

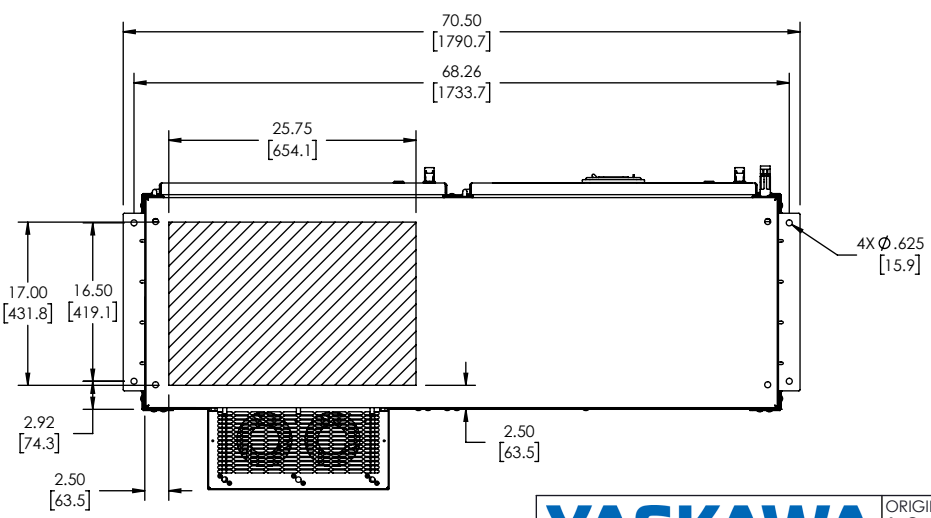
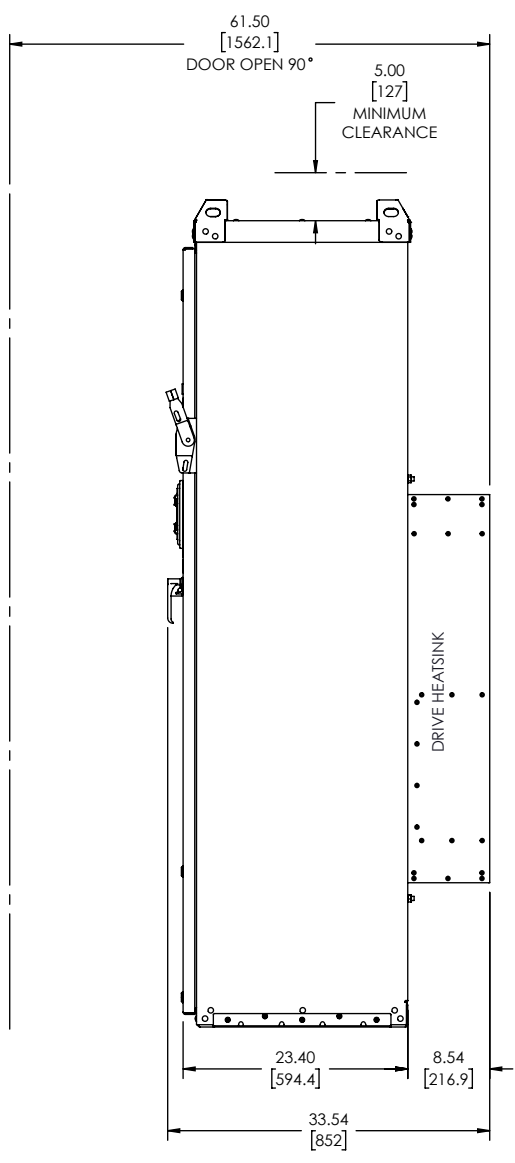
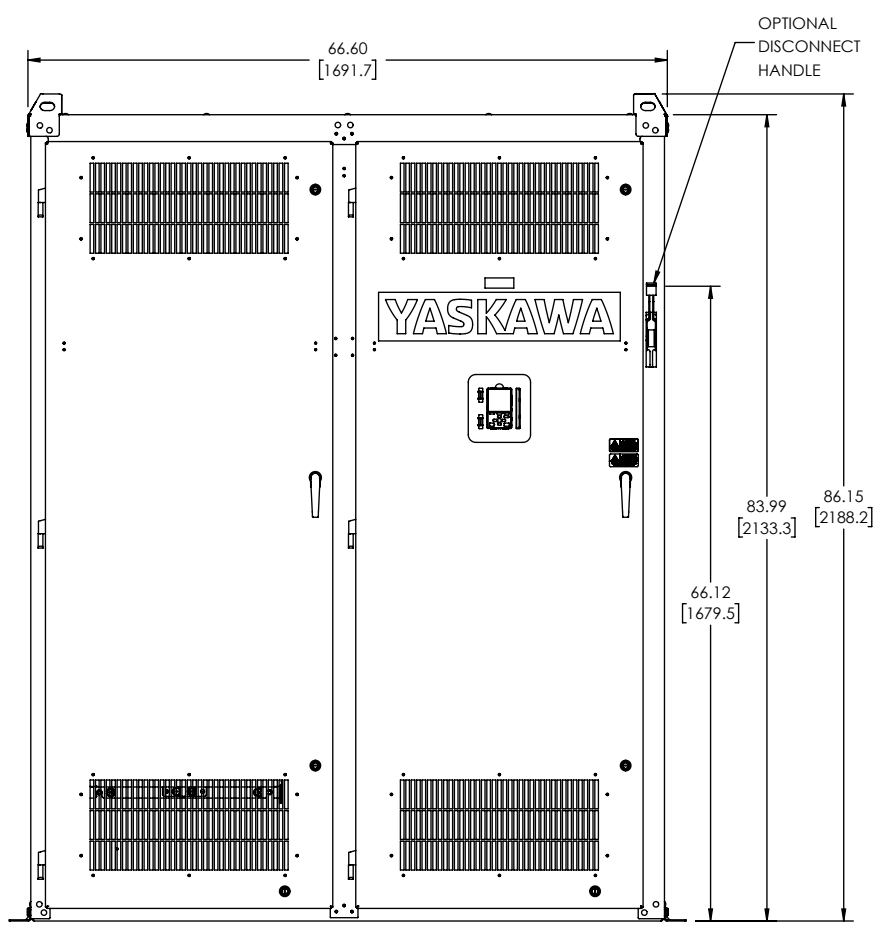
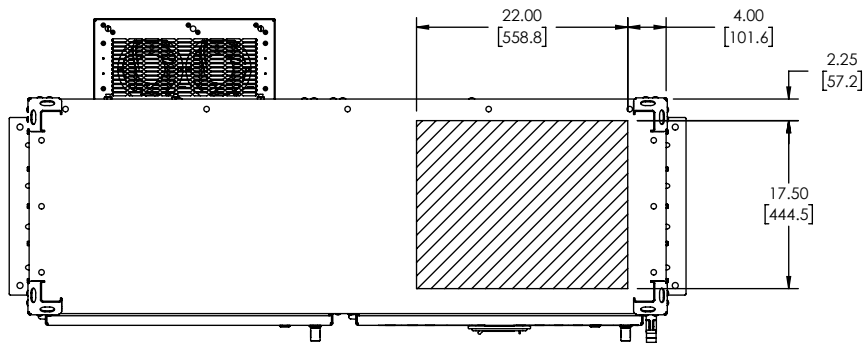

- NOTES:
- A. FOR REFERENCE UNLESS PROPERLY ENDORSED. FOR ADDITIONAL DETAILS AND SPECIFICATIONS, CONSULT YASKAWA AMERICA, INC.
 - B. DIMENSIONS ARE IN INCHES[MILLIMETERS].
 - C. USE APPROPRIATE TYPE RATED HUBS OR FITTINGS TO MAINTAIN ENCLOSURE RATING.
 - D. HATCHED AREA INDICATES PERMISSIBLE CONDUIT ENTRANCE AREA.
 - E. FANS, FILTERS AND/OR CLOSING PLATES ARE SUPPLIED AS NEEDED PER OPTION SELECTIONS.

YASKAWA

THIS DOCUMENT AND INFORMATION CONTAINED IN IT ARE CONFIDENTIAL AND CANNOT BE COPIED OR DISCLOSED IN WHOLE OR IN PART WITHOUT THE EXPRESS WRITTEN CONSENT OF YASKAWA AMERICA INC.

UNITS: INCHES	SCALE: NONE	ORIGINAL DESIGN: A. Guy	DATE: 04/27/2022	TITLE: DIMENSION DRAWING, HWF, F2, TYPE 1		
		DRAWN: A. Guy	DATE: 04/27/2022	SIZE: B	REVISION: 00	PAGE: 1 OF 2
		CHECKED: A. Jandrin	DATE: 04/27/2022	DRAWING #:		
		APPROVED: R. Jensen	DATE: 04/27/2022	DD.HWF.1.F2.01		



 <small>THIS DOCUMENT AND INFORMATION CONTAINED IN IT ARE CONFIDENTIAL AND CANNOT BE COPIED OR DISCLOSED IN WHOLE OR IN PART WITHOUT THE EXPRESS WRITTEN CONSENT OF YASKAWA AMERICA INC.</small>	ORIGINAL DESIGN: A. Guy	DATE: 04/27/2022	TITLE: DIMENSION DRAWING, HWF, F2, TYPE 1		
	DRAWN: A. Guy	DATE: 04/27/2022			
	CHECKED: A. Jandrin	DATE: 04/27/2022	SIZE: B	REVISION: 00	PAGE: 2 OF 2
	APPROVED: R. Jensen	DATE: 04/27/2022	DRAWING #:		
UNITS: INCHES	SCALE: NONE	DD.HWF.1.F2.01			